

TANK PLAN VIEW

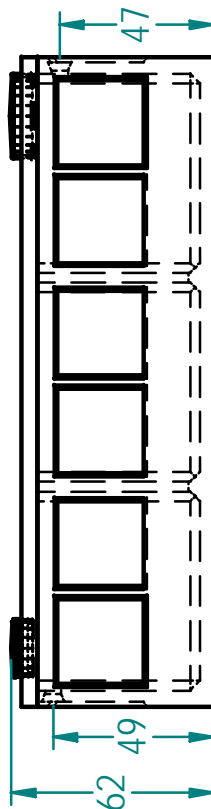

TANK ELEVATION VIEW

in  
| mm |

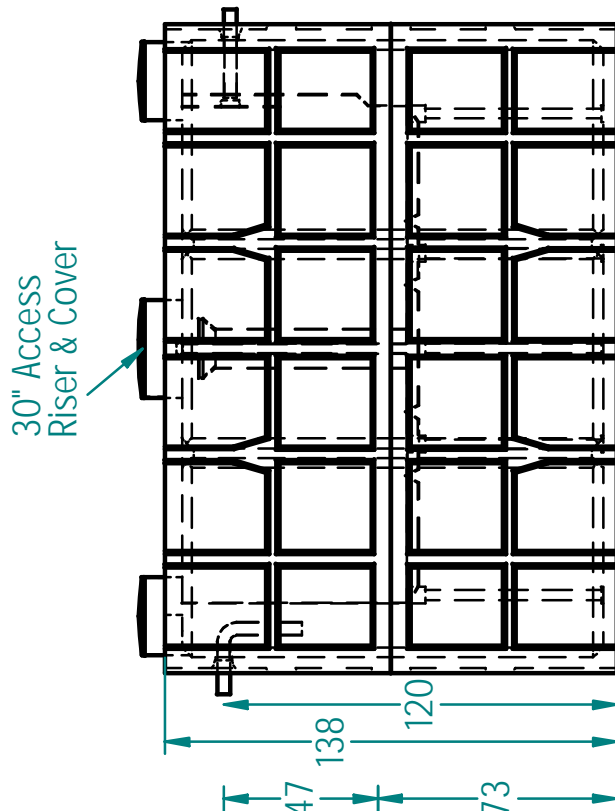

**Brooklin**  
QUALITY CONCRETE PRODUCTS

Brooklin (800)655-3430  
Newmarket (888)407-6443  
Huntsville (800)264-3302  
Haliburton (800)273-9084

# MicroFAST 9.0

## Flow Rate: 34,100 L/day



Tank Arrangement Drawing  
Tank Model: 7000-2PC-1CH  
2500-1PC-1CH

DRAWN BY: TD

DATE: 26 February/2007

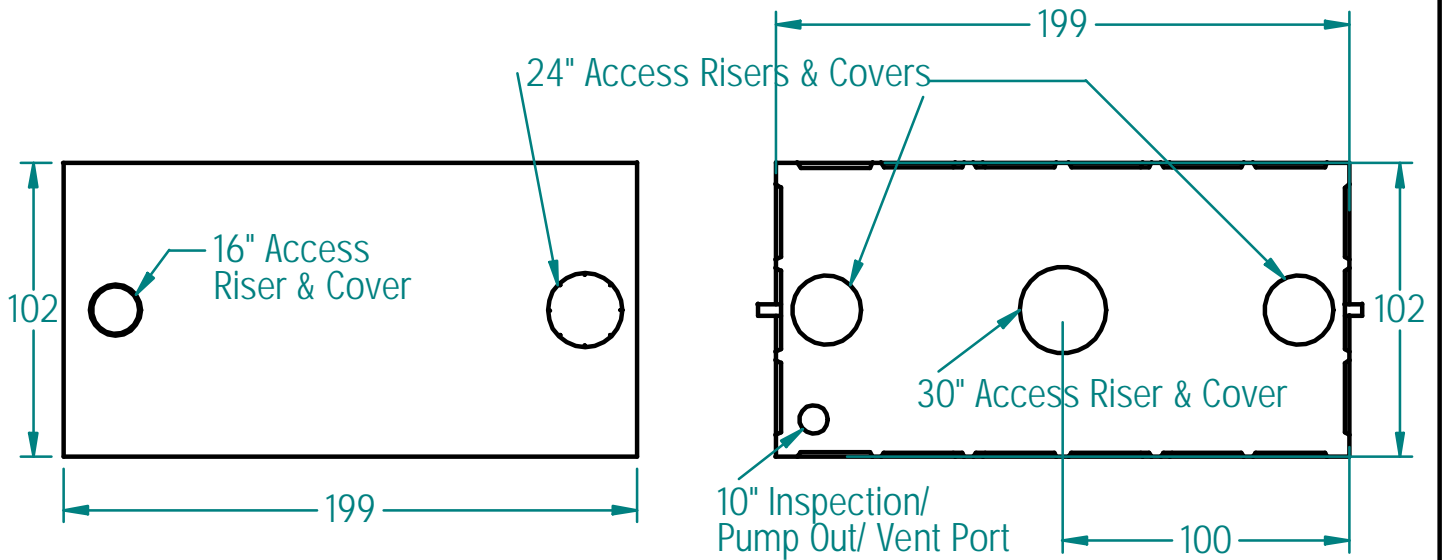

TANK LID PLAN VIEW

MicroFAST Model MCF 9.0  
 Daily Maximum Residential Sewage Flow:  
 7,500 imp gal  
 34,100 L

Maximum Biological Loading Rates:  
 250mg/L BOD  
 250mg/L TSS  
 <35mg/L Fat's, Oil's, Grease

Effluent Quality:  
 10mg/L BOD  
 10mg/L TSS  
 70% Reduction Total Nitrogen

Blower  
 5hp, 230v, 1ph or 3ph,  
 172-228 CFM Atmospheric Air

CONSULT PINNACLE FOR ALL  
 HIGH STRENGTH APPLICATIONS  
 (BOD or TSS > 250mg/L)

Trash Tank: 2500g  
 Treatment Chamber: 7000g Holding

The Tongue & Groove Joint Is Sealed With Flexible Butyl  
 Resin Sealant During Installation

180' of Equalizer 24 Chambers & End Caps to be  
 Installed With Each Unit For In Ground Venting  
**Maximum Burial Depth Of Infiltrator Is 15" (380mm)**

Concrete Properties: 4500 PSI (32 MPa) Min Strength  
 6-8% Air Entertainment

NonSulphate Soil Design Concrete

Inlet & Outlet polyseals accept up to 4" ABS pipe

**Maximum Burial Depth Of The Tank Is 30" (750mm)**

Trash Tank Shipping Weight: 26,550lbs (12,050Kg)  
 Treatment Chamber Shipping Weight:  
 Top Half - 21,415 (9715Kg)  
 Bottom Half - 21,840 (9910Kg)

in  
 |mm|



Brooklin (800)655-3430  
 Newmarket (888)407-6443  
 Huntsville (800)264-3302  
 Haliburton (800)273-9084

MicroFAST 9.0  
 Flow Rate: 34,100 L/day



Lid Plan View & Notes  
 Tank Model: 7000-2PC-1CH  
 2500-1PC-1CH

DRAWN BY: TD

DATE:26 February/2007